

FRICION STIR LAP WELDING OF DISSIMILAR ALUMINUM ALLOYS WITH COPPER PARTICLES ADDITIVES

Ghusoon Ridha Mohammed Ali*, Ethar Mohammed Mubarak and Rawaa Hamid Al-Kalali
Mechanical Techniques Department, Middle Technical University,
Institute of Technology, Baghdad, IRAQ
E-mail: ghusoon_ridha@yahoo.com

Emad Ali Hussein
Department of Production Engineering and Metallurgy, University of Technology, IRAQ

Friction stir lap welding (FSLW) of dissimilar Aluminum alloys (AA1100 with AA6061) is investigated using a 3 mm sheet's thick. These alloys are difference in physical characteristics, strength, and melting temperatures, at different tool rotation speeds (560, 900 and 1400) rpm and various feed rate (16, 40 and 125) mm/min, with cylindrical pin geometry having two tilt angle: 0°, 3° was used. Copper particles were added to the weld zone to make composite friction stir welded joints using the best welding conditions. Many tests and inspections were carried out to evaluate the joint quality and the soundness of weldments. The highest value of tensile strength and efficiency at (1400, 40, 3°) while hardness recorded (97.5 HV) at stir zone of FSLW and it go downs along the HAZ and base metals of AA1100 and AA6061.

Key words: friction stir lap welding (FSLW), micro hardness, copper, AA1100, AA6061.

1. Introduction

AA 1100 is characterized by its lower strength compared to other types of aluminum, which gives it better advantages, as it has been used in many engineering applications such as the electrical, chemical, and food manufacturing industries, in addition to its use in electric vehicle bars. As for AA6061, it is from the 6000 series of aluminum alloys, which is characterized by the addition of silicon and magnesium when casting, which increases its electrical conductivity in addition to high durability, and therefore it is used in the manufacture of conductors in electric rods [3-1]. Although the operational steps for making a lap joint and butt joint are generally similar, in lap joints the two plates needed to be joined are lied horizontally one above the other. This arrangement of placing plates implies extra sophistication regarding amount and nature of heat transferring between them. Furthermore, the increase in depth resulting from putting plate's one on top of the other requires a tool of longer pin in order to attain effective stirring [4, 5]. Similar to the case of butt weld, there are several factors in the lap weld FSW type that influence the welding quality and effectiveness. Such as operating factors, plate clamping fixture type, and tool downward force. Regarding air gap size, as air gap increases, weld quality decreases [6].

Lap joint is another technique, besides butt joint, employed for welding metals and it is called friction stir lap welding (FSLW). The welding process has to be controlled through a series of specifications and variables in order to obtain good quality joints. The variables relevant for this process are alloy category, the diameter of the tool shoulder ($D_{Shoulder}$) and of the tool pin (D_{pin}), length of the pin (L_{pin}), tilt angle of the tool (θ), rotational speed of the tool (ω) and tool transverse speed (v) [7].

Defects in pressure vessels occur due to lack of attention to the products and their quality during production such as welding, heat treatment, or forming methods. In the manufacturing process, different parts are

* To whom correspondence should be addressed

joined by welding or other joining methods when producing pressure vessels. Some defects such as discontinuity may occur, which is formed due to the stress associated with this area. The thickness and radius cause bending stress in the formed pressure vessels. In the discontinuity area, the stress distribution may change. These deformations are uneven in the welds [8, 9]. Study related with FSW has been checked on by Heidarzadeh *et al.* [10], Kumar *et al.* [11] and Shah *et al.* [12]. The study was generally concentrated on the butt joint's geometry and not so much on FSLW. The aspects covered insufficiently by contemporary studies are associated with integrity of structural and the relationships of the final microstructure-property of the welding in case of dissimilar materials. The present work is focused primarily on these topics. Cederqvist and Reynolds [13] provided a broad analysis which includes interface morphology and mechanical properties of lap joints obtained through FSW. For this study, the following materials were used: Al clad 2024-T3 was the upper plate and bare 7075-T6 as lowest plate. Kittipong and Takehiko [14] analyzed the FSW parameters in the following conditions: A 5083 aluminum alloy and plates steel SS400, lap joint of thickness 3 mm. The researchers explored the speed of rotational, speed of traverse and depth of tool pin impacts on the shearing load and the interfacing structure of the joint. Hong Liu *et al.* [15] analyzed the orientation of grain, properties of texture and mechanical for the lap joint obtained through FSW applied on stage 2 commercial pure titanium with thickness of 2 mm. In another study by H. Bisadi *et al.* [16], friction stir welding of 5083 aluminum lap joint carried out where using varied values of (32, 60 mm/min welding speed) and (600, 825, 1115, 1550 rpm rotational speed) to investigate their impact on metallurgical and mechanical characteristics of the resulting weldments.

Navdeep Singh *et al.* [17] Analyzed micro hardness, tensile characteristics and micro-structure of FSW butt joints. For this purpose, AA 1100 and AA 6101-T6 aluminum alloy sheets with thickness 6 mm, high speed and two tool shapes "Straight Cylindrical (SC) and Square Thread (ST)" were used. The purpose of the research was to explore the impact of tool design and rotation speed on the outward form of stir zone. Limited researches carried out on dissimilar aluminum alloys (AA6061 to AA1100) lap joints using friction stir welding process. Enhancement of mechanical properties of FSLW joints can be carried out by reinforcing the weld zone with copper powder.

2. Experimental work

2.1. Dissimilar materials of friction stir lap welding

Friction stir welding (FSW) of Lap joint has been used in this paper for dissimilar materials (Fig.1). Aluminum alloys, AA1100 and AA6061, with (3mm) thickness where the material AA1100 is placed above AA6061 (Fig.2) as it shows significantly higher fatigue ductility than any other alloy. The parameters were selected according to what is found in previous researches [5] and studied in FSW process are (rotation speed, feed rate and tilt angle of tool) as presented in Tab.1. Chemical composition of Al-Alloy AA1100 and AA6061 illustrated in Tabs 2 and 3.

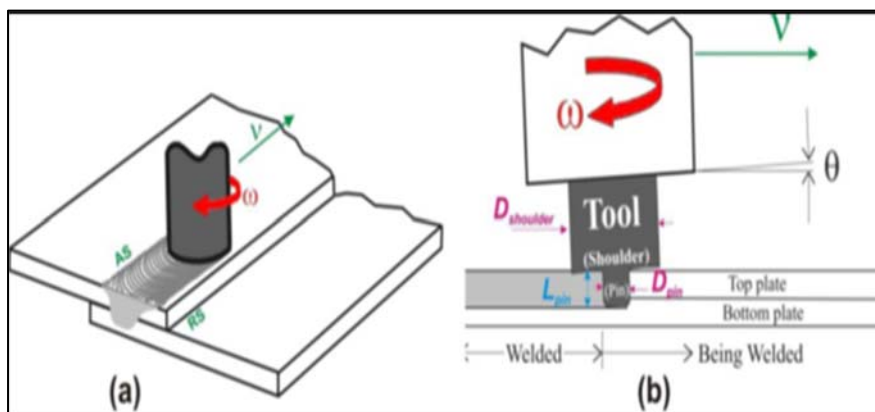

Fig.1. (a) Process of FSLW (b) different parameters of FSLW [18].

Table 1. Parameters used in study.

speed of spindle (<i>rpm</i>)	560	900	1400
feed rate (<i>mm/min</i>)	16	40	125
tool angle ($^{\circ}$)	0°	3°	-

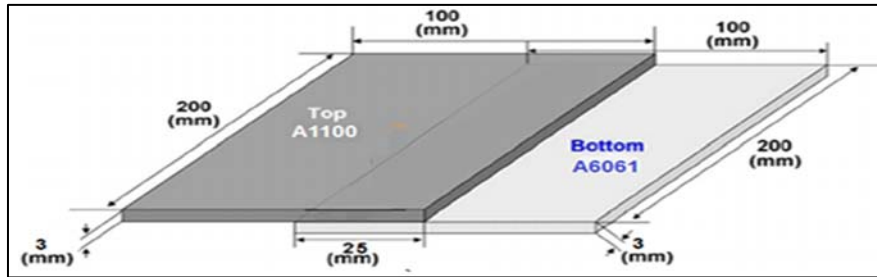

Fig.2. Dissimilar Al-alloys for lap welding.

Table 2. Chemical composition of AA1100.

Element wt.%	Si	Cu	Mn	Mg	Cr	Ni	Zn	Ti	I
AA6061	0.593	0.154	0.003	Nil	0.0019	0.0016	0.006	0.003	al.

Table 3. AA6061 Chemical composition.

Element wt.%	Si	Fe	Cu	Mn	Mg	Cr	Ni	Zn	Ti	I
AA6061	0.539	0.532	0.303	0.092	0.921	0.209	0.0122	0.064	0.016	al.

2.2. Cu powder

Dendrite clusters grains is the type of Cu powder particles size 211.2 nm as the grains mean diameter used as a factor to improve the FSL welding joint quality and two mechanisms were used to add the Cu powder firstly by filling a V-shape groove $3.5 \text{ mm} \times 1 \text{ mm}$, performed at the bottom plate with Cu powder, which shown in Fig.3, secondly by making a colloidal consists of ethanol liquid and Cu powder to coat the prepared surfaces.

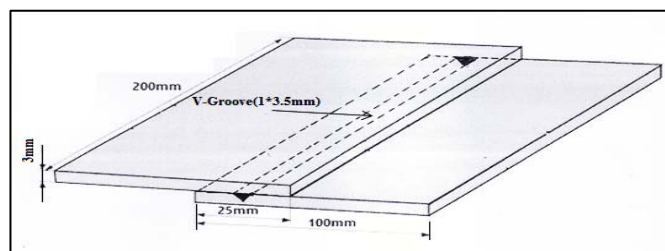

Fig.3. Work piece dimensions & groove location.

2.3. Tool geometry

Device geometry is the foremost compelling impact of process evolution. It indicated a complicated role in the flow of material with circuit controls the rate of traverse that FSLW would be managing, like in Fig.4. The device has two essential capacities: (a) localized warming, and (b) flow of metal.

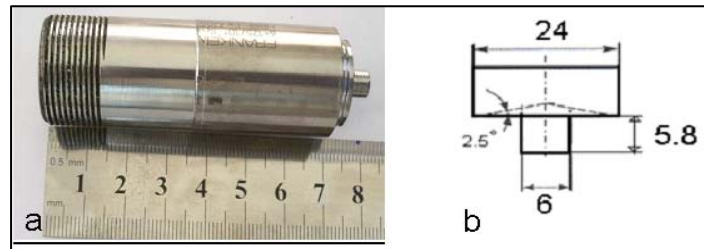

Fig.4. Welding tool.

Within the beginning organize of apparatus mixing, the warming produces at first from the friction between tool and work piece. A few extra warming produces from deformation of metals. The device is so used until the touches of shoulder with the work piece. The friction between the shoulder and work-piece comes about within the greatest previous of warming [19]. From the warming effect, the proportionality of pin size shoulder is momentous, and the other plan highlights were not complicated. The shoulder moreover serves restriction for the warmed metal measurement. The second reason of the instrument is to ‘stir’ and ‘move’ the metal. The tool design is administered on the microstructure and process of loads [20].

2.4. Fixtures and anvil manufacturing

An installation and back plate were particularly made to support the sheets that welding using table of milling machine. Four separate fixtures, two to fix every sheet side, and low carbon steel as a back plate with dimensions of $250 \times 250 \times 20$ mm were made according to work requirement. Both faces of this plates were ground in order to produce parallel surfaces, which is important in this stage, and involving four threaded holes $M8 \times 1.25$ to fix the AA1100 plate over the AA6061 with overlap of 25 mm and square cross section rod welded on the upper face of the back plate work as a counter stopper to the work piece movement as shown in Fig.5.

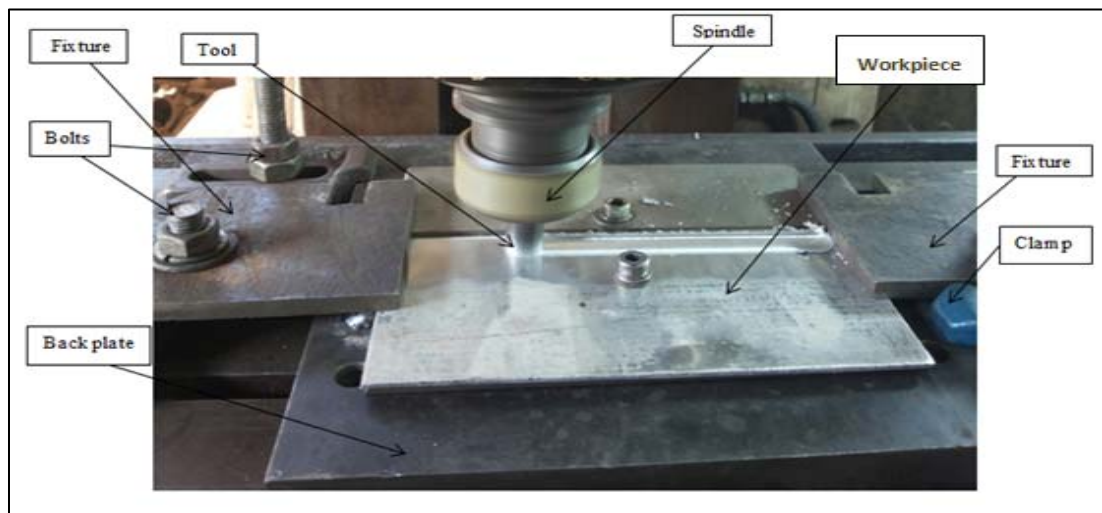

Fig.5. Clamp and fixture system, welding tool and work piece.

2.5. Measuring the temperature

During the process of FSW, temperatures are recorded in three places by three thermocouples. The thermocouples located at 40 mm from the centerline of the weld and the locations of the three points were illustrated in Fig.6.

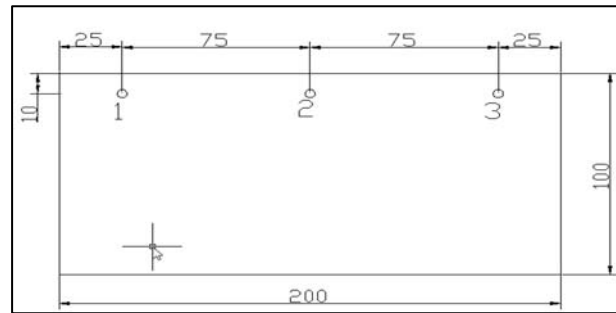

Fig.6. Layout of the locations of the thermocouples (units in *mm*).

2.6. Friction stir lap welding process procedure

Because of the need of special machine for stir welding, the milling machine was utilized. It was employed with different feed and speeds of rotation and tilt angle of pin. The machine has been prepared with instrument, backing plate and installation to be suitable for FSLW process where the procedure has been carried out as follows steps:

1-fixed thermocouples,

at first the holes is made with depth (1mm) in three locations at Al-alloy AA1100 sheet by using drilling machine, as shown in Fig.7, for all sheets to planting thermocouples and measuring the temperature during welding process.

2-fixed sheets,

FSLW process was utilized to build up dissimilar lap joints of (AA1100 to AA6061-T6). The AA1100 alloy plate is selected at the upper since it had a weak mechanical properties like hardness is low also tensile strength is low while comparing with AA6061 alloy sheet.



Fig.7. Machine and sample setup.

After practical testing is done, the samples are fixed then mounted using particular brackets and screws with fixtures. The tool pin rotated with (CW) at the specific rate and was permitted to touch the plate at the upper side and penetrate gradually about 9% of plates thickness which is 5.8 mm till the shoulder starting touch the work piece top surface and penetrates to 0.1 mm to applied the required pressure for welding saving the pressure about 30 sec (dwell time) till the flash of metal is extruded around the instrument. Then the tool of rotating is moved towards the border of plates at a certain speed of welding till coming to the end of work piece. Hence the instrument will be pulled back.

3. Results and discussion

3.1. Distribution of temperature

The design of the tool impacts the generated heat, plastic flow, the requirement of power, and the consistency of welding joint. Most of heat is generation by the shoulder, that the metal flow affected by the shoulder and the pin of tool. Movement due to revolution and translating the tool actuates symmetry within the flow of metal and warming over the pin [20]. The speed of rotated tool coming to stir and mingle the metal over the tool and the moving of tool will stir the metal from the front to the back of the tool and ended the process of welding. High rates of speed of revolution make high temperature since of high friction warming that coming to more effective stir and mingle of metal. Hence, it shown that the friction between the surface of the tool and work piece is controls the heating. After recorded temperatures for 18 samples during welding process at three locations the results were shown in Tab.4.

Table 4. Recorded temperatures.

Seq.	Rotation speed ω (rpm)	Feed rate (mm/min)	Angle of tool θ°	T1(C°)	T2 (C°)	T3 (C°)
1	560	16	0	204	284	304
2	560	40	0	193	223	293
3	560	125	0	127	226	251
4	900	16	0	176	292	370
5	900	40	0	250	325	345
6	900	125	0	149	260	277
7	1400	16	0	207	316	355
8	1400	40	0	229	366	438
9	1400	125	0	208	281	374
10	560	16	3	200	277	311
11	560	40	3	204	218	265
12	560	125	3	104	168	185
13	900	16	3	116	156	247
14	900	40	3	160	276	315
15	900	125	3	96	198	198
16	1400	16	3	132	130	140
17	1400	40	3	220	308	397
18	1400	125	3	180	200	270

3.2 The results of visual inspections

The visual inspections are utilized before, during and after the process of welding. In this inspection many defects evaluated directly using eye.

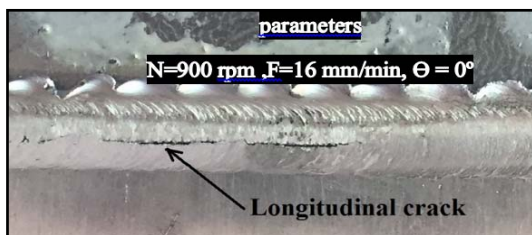

Fig.8. Longitudinal crack.



Fig.9. Flash formation.

- The weld line surface either the defects present that are due to tool or heel of shoulder showed in Fig.8.
- Metal flash overflowing since too much depth of plunging tool as illustrated in Fig.9.
- Weld faces smoothness present in Fig.10.
- Figure 11 illustrated the welding misalignment and surface cracks at the back, and lack of penetration (LOP).

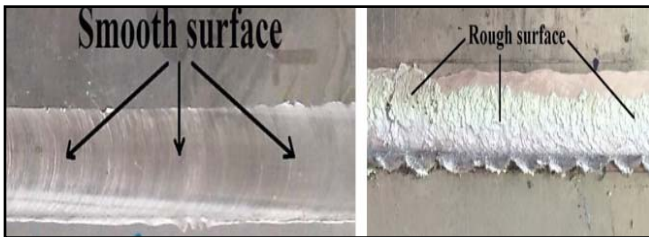

Fig.10. Smoothness of weld face.



Fig.11. The misalignment of weld.

It can be seen from Fig.12 that some cases have defects result from the FSLW, which are the tunnel, that's due to defective stir effect of the metals through the process, insufficient preparation of surface, lack of penetration of the pin and non-uniform vertical forging powers towards the thickness of metal [21]. Since this tunnel defect (Fig.13.), the stress analysis around the tunnel hole is concentrated and the damaged and the joint fracture would develop without necking and the damage was simply by fracturing during the bottom side of the nugget and near the surfaces of the entire joint [22-24].

After VI test, eight samples were excluded. In Fig.12 the eight valid samples will be presented with their parameters:

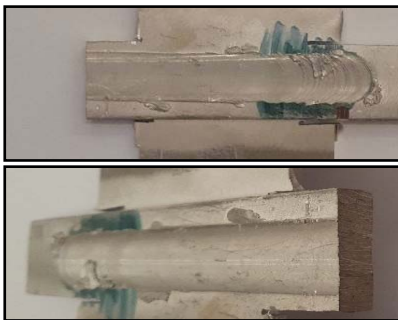

$\omega = 560$, feed = 40 , $\theta = 0^\circ$

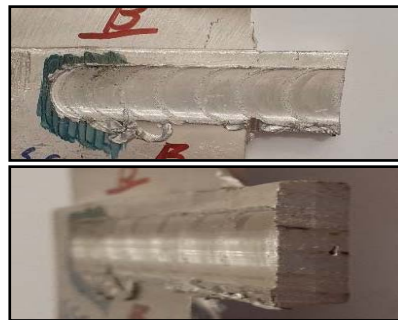

$\omega = 900$, feed = 16 , $\theta = 0^\circ$



$\omega = 560$, feed = 16 , $\theta = 0^\circ$



$\omega = 1400$, feed = 125 , $\theta = 0^\circ$

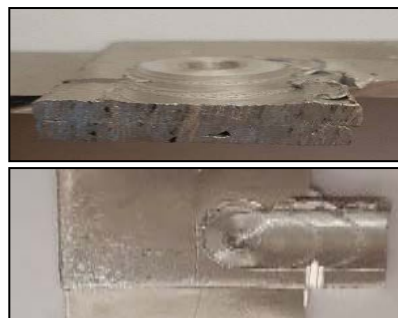

$\omega = 1400$, feed = 40 , $\theta = 0^\circ$

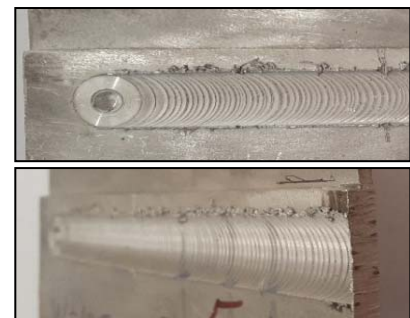

$\omega = 1400$, feed = 40 , $\theta = 3^\circ$

Fig.12. The valid sample.

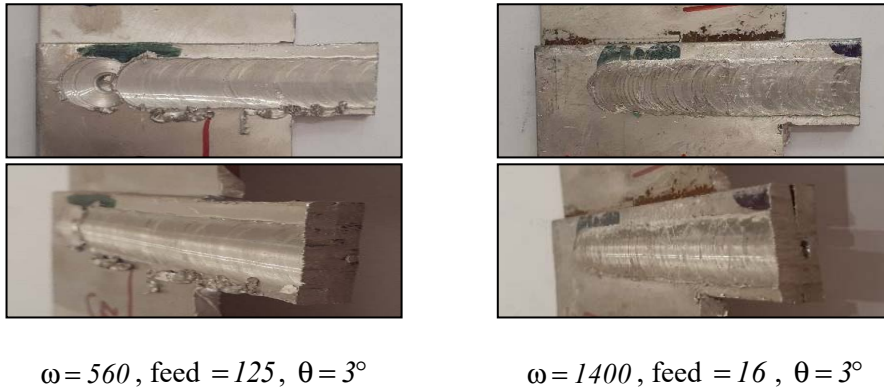

Fig.12 cont. The valid sample.



Fig.13. Tunnel defect.

3.3. Impact of rotational speed of tool on the tensile strength

The dis-similar FSLW joints includes fixed travel speed of 40 mm/min and $\theta = 3^\circ$, have been taken with tool rotation speed of $560, 900, 1400 \text{ rpm}$. Maximum weld efficiency reached 91.7% and tensile force of 4.86 kN when using rotational speed of 1400 rpm , as shown in Fig.14. This result explains clearly the high heat input at fixed travel speed and high rotation of speed 1400 rpm .

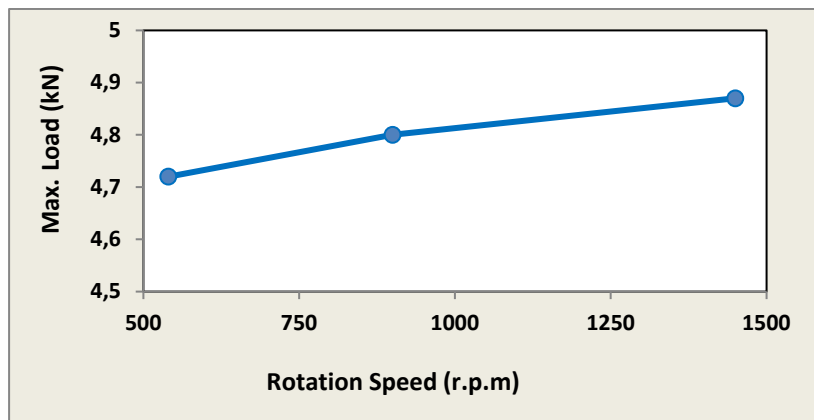

Fig.14. Effect of tool rotation speed on tensile force.

3.4. Effect of feed rate on tensile force

The penetration of pin into upper AA1100 sheet results heat flow and heat transfer to lower sheet AA6061 due to thermal conductivity of Al alloys and by applying the axial load on the shoulder result a good diffusion bonding joint and gave higher joint efficiency than the conventional FSLW joints [25, 26].

Figure 15 displays stress-strain curve of AA6061 & AA1100 materials and Tab.5, represents the max. Tensile force and the efficiency's joint of dissimilar FSLW joints.

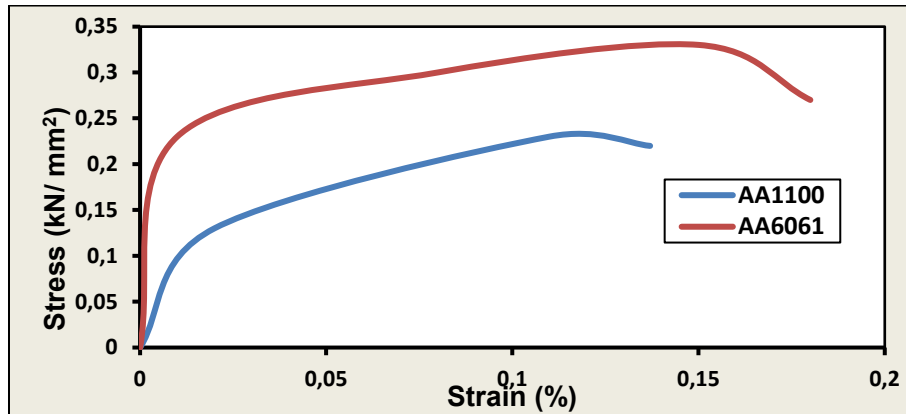

Fig.15. Stress-strain curve of AA6061 and AA1100 materials.

Table 5. FSLW for dissimilar Al alloys (1100 to 6061).

feed rate <i>mm/min</i>	rotational speed ω <i>rpm</i>	angle of tool θ°	max. force <i>kN</i>	joint efficiency <i>%</i>
16	560	0	4.21	86.6%
16	900	0	4.33	89.5%
16	1400	0	4.26	92%
40	560	0	4.12	89%
40	900	0	4.53	90.8%
40	1400	0	4.59	91.5%
125	560	0	4.55	83.5%
125	900	0	3.98	78.8%
125	1400	0	3.88	72.3%
16	560	3	4.51	87.6%
16	900	3	4.83	90.5%
16	1400	3	4.66	92.2%
40	560	3	4.72	90%
40	900	3	4.93	92.8%
40	1400	3	4.9	93.8%
125	560	3	4.44	89.8%
125	900	3	4.11	89.5%
125	1400	3	3.91	83.3%

3.5. Effect of Cu powder addition

In this case FSLW was performed for (1100+Cu powder +6061) under the best welding conditions, 900 rpm and 40 mm/min. and pin length 5.8 mm. Figure 16 shows the SEM image and particle size distribution of cu powder was 198.52 nm while the shape of Cu powder was dendrite shape. The investigation using SEM was utilized to the topography of surface at the interface of the welding specimens at best parameters. In addition to fracture surface analysis of failure welded joints was investigated.

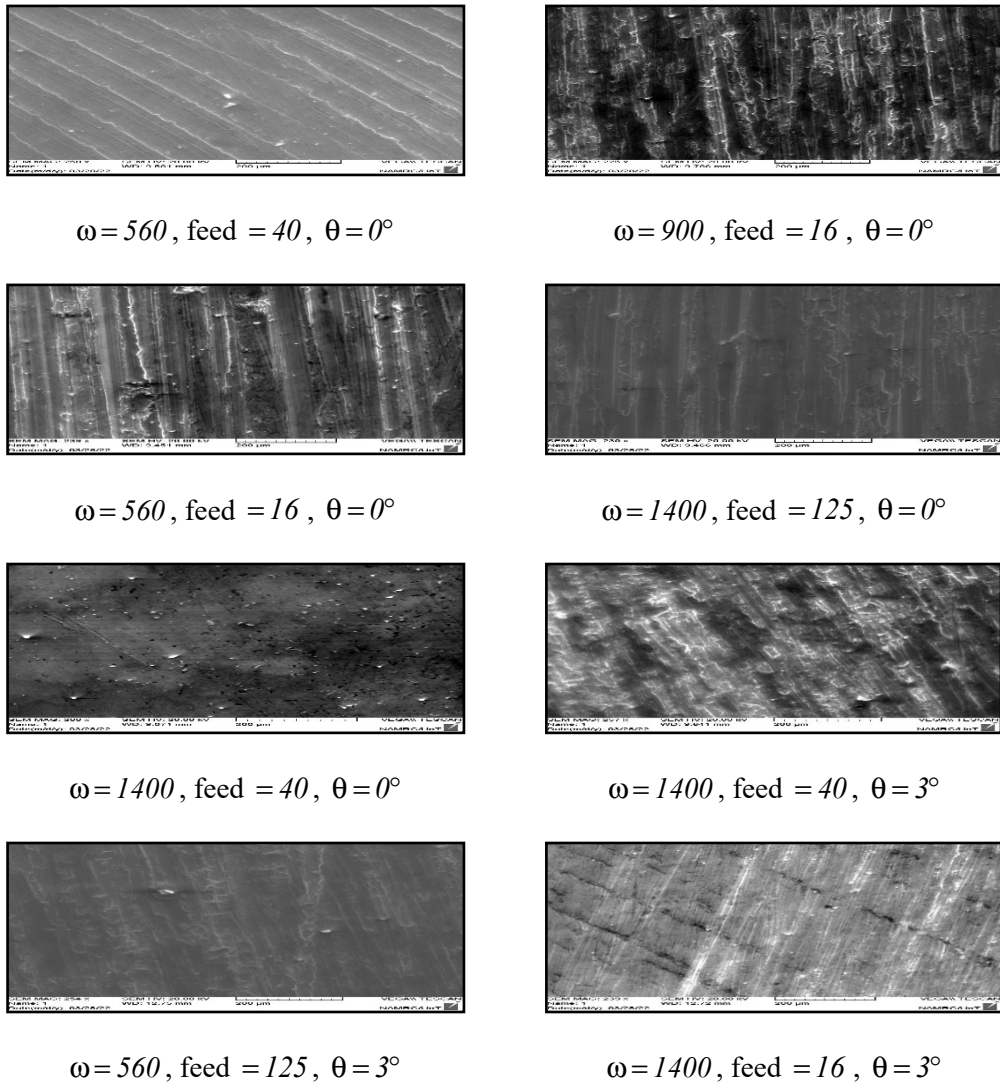

Fig.16. SEM image for welded dissimilar materials.

Figure 17 shown SEM photomicrograph with the Cu agglomerates and particles distribution at the interface of Dissimilar between AA1100 and AA6061 plate at $\omega = 1400$ rpm, feed = 40 mm/min, $\theta = 3^\circ$.

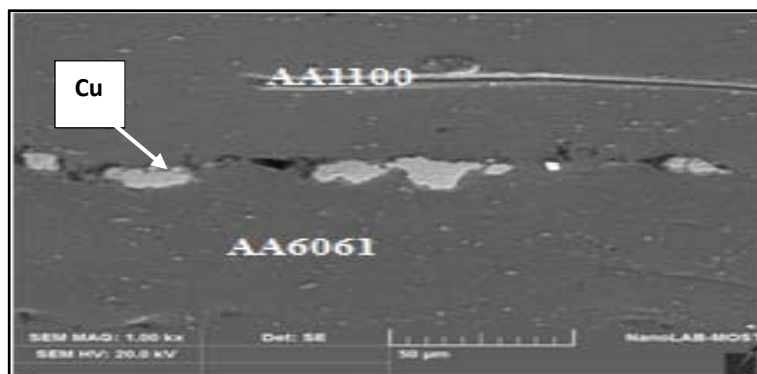

Fig.17. Cu particle in the welded plate.

4. Hardness results

There is large difference in the hardness distribution between two sides of dissimilar welds (1100 with 6061) this is due to difference in strengthening mechanism between 1100 side and 6061 side [27-29]. Figure 18 shows the distribution of hardness through joint at the optimal conditions of welding, 1400 rpm, 40 mm/min and $\theta = 3^\circ$. Hardness varied between 97.5 HV and 32.5 HV. Hardness recorded lower value (32.5HV) at AA1100 metal and the base metal of AA6061 listed 62 HV and start to increase a little along the heat affected zone of the front and backward part. The stir zone hardness was high than other welded zones 97.5 HV. That due to the formation of very fine re-crystallized grains in the stir zone [11, 30].

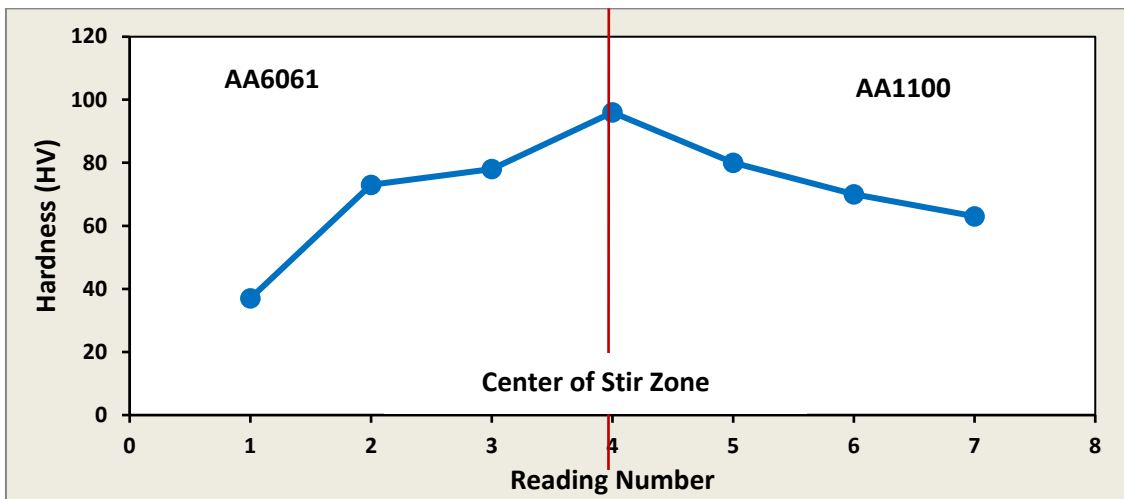

Fig.18. Hardness distribution in the cross section of the dissimilar FSLW joint.

Figure 19 indicates to the micro hardness measuring out in the cross-section of the dissimilar FSLW joint reinforced with copper particles at the best welding conditions, hardness varied between 89.88 HV and 31.5 HV. The lowest value of hardness recorded at base metal of (AA1100) and (AA6061) is 64 HV and 31.5 HV respectively. Growth of grain is the extreme suitable since of this region. The hardness of stir zone was the highest (89.88 HV). Since the formation of very fine re-crystallized grains in the stir area also reinforced phase's formation due to Cu particles addition [31-33].

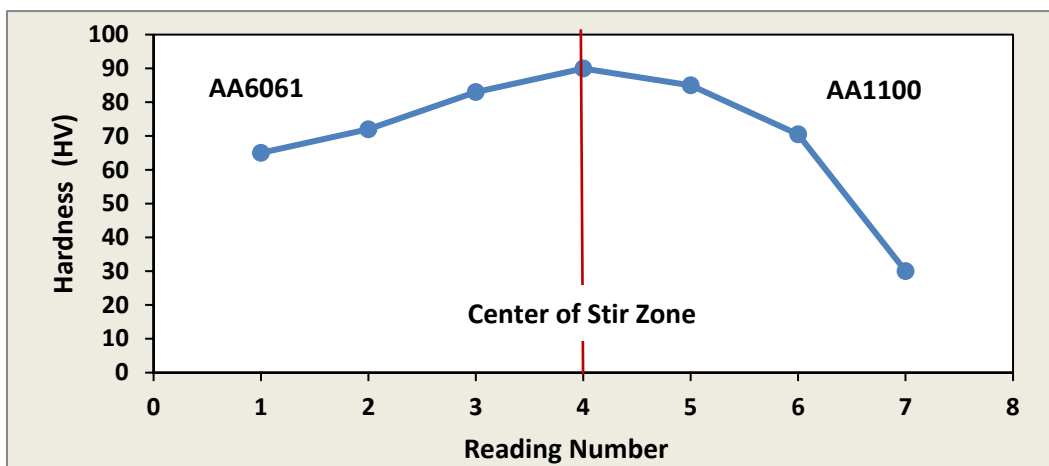

Fig.19. Distribution of micro hardness in the dissimilar FSLW joint reinforced with copper particles.

5. Conclusions

1. The insufficient heat input for stirring during FSLW results in many defects such as voids, tunnels, incomplete fusion, flash... etc.
2. The rotating speed of welding machine have the highest effect on the determination the tensile strength efficiency of weldment as comparing with the travel speed.
3. Lower and higher ranges of rotating speed gives the higher ranges of tensile strength efficiency of welded.
4. The topmost tensile strength and efficiency values were found at $(1400, 40, 3^\circ)$ and the lowest at $(1400, 125, 0^\circ)$.
5. It was observed that tensile strength become higher while rising tool rotation and lessening welding speed to end up at the highest number of it and then decreases again.
6. The value of hardness was $(97.5 HV)$ in stir area and it fall down across heat affected zone and metals of AA1100 and AA6061.

Recommendations for future research work can be considered like residual stress and distortion effects as they are primarily influenced by the welding parameters, material properties and design considerations. These cause dimensional accuracy, stability and long-term performance of the welded structure.

Nomenclature

- FSLW* – friction stir lap welding
D_{Shoulder} – diameter of the tool shoulder
L_{pin} – length of the pin
D_{pin} – diameter of the tool pin
 θ – angle of tool
 ω – rotation speed
LOP – lack of penetration
SEM – scanning electron microscope

References

- [1] Ghusoon R.M., Rawaa H.M. and Basim H.A. (2019): *Effect of die geometry on thermal fatigue of tool steel in aluminium alloy die-casting.*– IOP Conference Series: Materials Science and Engineering, vol.518, No.3, p.032042, <https://doi.org/10.1088/1757-899x/518/3/032042>.
- [2] Kumar P.R. and Raj R.G. (2014): *A review on friction stir weldment of AA6061 and AA1100 aluminium alloys.*– Int. J. Adv. Inf. Sci. Technol, vol.3, pp.104-108.
- [3] Budak S., Çolak H. and Yakut Y. (2023): *Effect of aging time and temperature on microstructure and mechanical properties of AA7075 alloy.*– Gümüşhane Üniversitesi Fen Bilimleri Dergisi, vol.13, No.1, pp.23-31, <https://doi.org/10.17714/gumusfenbil.1099882>.
- [4] Leon J.S. and Jayakumar V. (2019): *An investigation of analytical modelling of friction stir welding.*– Int. J. Mech. Prod. Eng. Res. Dev, vol.9, No.1, pp.179-189, <https://doi.org/10.24247/ijmperdfeb201918>.
- [5] Mallieswaran K., Padmanabhan R. and Balasubramanian V. (2018): *Friction stir welding parameters optimization for tailored welded blank sheets of AA1100 with AA6061 dissimilar alloy using response surface methodology.*– Adv. Mats. Proc. Technols., vol.4, No.1, pp.142-157, <https://doi.org/10.1080/2374068X.2017.1410690>.

- [6] Yang Z., Wang, Y. Domblesky J. P., Li W. and Han J. (2021): *Development of a heat source model for friction stir welding tools considering probe geometry and tool/workpiece interface conditions.*– Int. J. Adv. Manuf. Technol, vol.114, pp.1787-1802, <https://doi.org/10.1007/s00170-021-06985-9>.
- [7] Zhang Y.N., Cao X., Larose S. and Wanjara P. (2012): *Review of tools for friction stir welding and processing.*– Canadian Metallurgical Quarterly, vol.51, No.3, pp.250-261, <https://doi.org/10.1179/1879139512Y.0000000015>.
- [8] Sreelakshmi M. and Pany C. (2016): *Stress analysis of metallic pressure vessels with circumferential mismatch using finite element method.*– Int. J. of Sci. Eng. Res., vol.7, No.4, pp.479-484.
- [9] Pany C. (2021): *Structural analysis of metallic pressure vessels with weld sinkage in the circumferential joint.*– J. Sci. Technol. Eng. Res., vol.2, No.1, pp.4-10.
- [10] Heidarzadeh A., Mironov S., Kaibyshev R., Çam G., Simar A., Gerlich A., Khodabakhshi F., Mostafaei A., Field, D.P., Robson J.D., Deschamps A. and Wither P.J. (2021): *Friction stir welding/processing of metals and alloys: A comprehensive review on microstructural evolution.*– Prog. Mats. Sci., vol.117, p.100752, <https://doi.org/10.1016/j.pmatsci.2020.100752>.
- [11] Kumar Rajak D., Pagar D.D., Menezes P.L. and Eyvazian A. (2020): *Friction-based welding processes: friction welding and friction stir welding.*– J. Adh. Sci. Technol, vol.34, No.24, pp.2613-2637, <https://doi.org/10.1080/01694243.2020.1780716>.
- [12] Shah P.H. and Badheka V.J. (2019): *Friction stir welding of aluminium alloys: An overview of experimental findings – process, variables, development and applications.*– Proceedings of the Institution of Mechanical Engineers, Part L: Journal of Materials: Design and Applications, vol.233, No.6, pp.1191-1226, <https://doi.org/10.1177/1464420716689>.
- [13] Cederqvist L. and Reynolds A. (2001): *Factors affecting the properties of friction stir welded aluminum lap joints.* Welding Journal-New York, vol.80, No.12, p.281.
- [14] Kimapong K. and Watanabe T. (2005): *Lap joint of A5083 aluminum alloy and SS400 steel by friction stir welding.*– Mats. Trans., vol.46, No.4, pp.835-841, <https://doi.org/10.2320/matertrans.46.835>.
- [15] Liu H., Nakata K., Yamamoto N. and Liao J. (2010): *Grain orientation and texture evolution in pure titanium lap joint produced by friction stir welding.*– Materials Transactions, vol.51, No.11, pp.2063-2068, <https://doi.org/10.2320/matertrans.m2010242>.
- [16] Bisadi H., Tour M. and Tavakoli A. (2011): *The influence of process parameters on microstructure and mechanical properties of friction stir welded Al 5083 alloy lap joint.*– American Journal of Materials Science, vol.1, No.2, pp.93-97, <https://doi.org/10.5923/j.materials.20110102.15>.
- [17] Singh N., Singh R. and Lal H. (2013): *Experimental study of friction stir welding of aluminium alloy (A1100 & A6101).*– Int. J. Adv. Sci. Technol (IJAST), vol.1, No.1, (December 2013).
- [18] Abbass M.K. and Raheef K.M. (2018): *A study of diffusion phenomenon in friction stir lap welding joints for low carbon steel C10 to aluminum alloy AA1100-H112.*– Al-Nahrain Journal for Engineering Sciences, vol.21, No.4, pp.479-485, <http://doi.org/10.29194/NJES.21040479>.
- [19] Shaojun Y.G.M.H.L. and Wanqi Q.Y.J. (2012): *Microstructures and room temperature mechanical properties of Al-6.3 Zn-2.8 Mg-1.8 Cu casting aluminum alloy.*– Acta Metall Sin, vol.48, No.2, pp.211-219, <https://doi.org/10.3724/sp.j.1037.2011.00579>.
- [20] Doğan K., Acarer M., Eker Y. and Salur E. (2022): *Microstructural and mechanical properties of AA7075 Al alloys produced via mechanical alloying process.*– Avrupa Bilim ve Teknoloji Dergisi, vol.35, pp.54-61, <https://doi.org/10.31590/ejosat.1041205>.
- [21] Leal R.M. and Loureiro A. (2004): *Defects formation in friction stir welding of aluminium alloys.*– Mats. Sci. For., vol.455-456, pp.299-302, <https://doi.org/10.4028/www.scientific.net/MSF.455-456.299>.
- [22] Venkit H. and Selvaraj S.K. (2022): *Review on latest trends in friction-based additive manufacturing techniques.*– Proceedings of the Institution of Mechanical Engineers, Part C: Journal of Mechanical Engineering Science, vol.236, No.18, pp.10090-10121, <https://doi.org/10.1177/09544062221101754>.
- [23] Liu J., Wu B., Wang Z., Li C., Chen G. and Miao Y. (2023): *Microstructure and mechanical properties of aluminum-steel dissimilar metal welded using arc and friction stir hybrid welding.*– Mats. & Des., vol.225, p.111520, <https://doi.org/10.2139/ssrn.4266681>.

- [24] Miah M.H., Chand D.S. and Malhi G.S. (2023): *The influence of tool rotational speed on microstructure and mechanical performance of dissimilar FSLW.*– Materials Today: Proceedings, <https://doi.org/10.1016/j.matpr.2023.03.454>.
- [25] Britto A.S.F. and Binoj J.S. (2022): *Mechanical properties optimization and microstructures of diffusion bonded AA2014/AA7075 al alloys.*– Rev. Meta., vol.58, No.3, e225, <https://doi.org/10.3989/revmetalm.225>.
- [26] Gowthaman P. and Saravanan B. (2021): *Determination of weldability study on mechanical properties of dissimilar Al-alloys using friction stir welding process.*– Materials Today: Proceedings, vol.44, pp.206-212, <https://doi.org/10.1016/j.matpr.2020.08.599>.
- [27] Ma H., Qin G., Zhao Q. and Geng P. (2022): *Correlation of heterogeneous interface microstructure and mechanical performance of inertia friction welded 6061 Al alloy joint.*– J. of Mats. Res. and Technol., vol.17, pp.166-183, <https://doi.org/10.1016/j.jmrt.2021.12.120>.
- [28] Sun Y., Tsuji N. and Fujii H. (2016): *Microstructure and mechanical properties of dissimilar friction stir welding between ultrafine grained 1050 and 6061-t6 aluminum alloys.*– Metals, vol.6, No.10, p.249, <https://doi.org/10.3390/met6100249>.
- [29] Chada R. and Kumar N.S. (2022): *Micro structural characteristics of dissimilar friction stir welds between AA7475-T7651 and AA6061-T6 aluminium alloys.*– AIP Publishing, <https://doi.org/10.1063/5.0081791>.
- [30] El-Sayed M.M., Shash A.Y., Abd-Rabou M. and ElSherbiny M.G. (2021): *Welding and processing of metallic materials by using friction stir technique: A review.*– J. Adv. Join. Procs., vol.3, p.100059, <https://doi.org/10.1016/j.jajp.2021.100059>.
- [31] Haghshenas M. and Gerlich A.P. (2018): *Joining of automotive sheet materials by friction-based welding methods: A review.*– Eng. Sci. Technol., Int. J., vol.21, No.1, pp.130-148, <https://doi.org/10.1016/j.jestch.2018.02.008>.
- [32] Cabibbo M., Forcellese A., Santecchia E., Paoletti C., Spigarelli S. and Simoncini M. (2020): *New approaches to friction stir welding of aluminum light-alloys.*– Metals, vol.10, No.2, p.233, <https://doi.org/10.3390/met10020233>.
- [33] Safeen M.W. and Russo Spena P. (2019): *Main issues in quality of friction stir welding joints of aluminum alloy and steel sheets.*– Metals, vol.9, No.5, p.610, <https://doi.org/10.3390/met9050610>.

Received: March 23, 2024

Revised: August 22, 2024